

INFRALAN®



Cat.6_A Component Certified
PVP-certified

The high-quality of the INFRALAN® RJ45 keystone modules slimline warrants very good characteristics for 10Gbit Ethernet application.

Special tools are not needed. The assembling is being carried out fast and easy. With the INFRALAN® RJ45 module slimline you get a full shielded module, which provides you good longterm service in your network infrastructure.

Specifications

- Shielded keystone zinc diecast body
- Cat.6_A component certified acc. to ISO/IEC 11801 Ed.2.2 (2011-06) and IEC 60603-7-51 Ed.1.1 (2010-03)
- Compact cable presorter for contacting IDC-Terminals AWG 26/1 .. 22/1 and AWG 26/7 .. AWG 24/7
- Re-termination capability up to 5 times with the same width
- Max. cable diameter: 8,5mm
- Pair management according to TIA 568A /B colour codes
- PoE and PoE Plus according to IEEE802.3af/at
- Appropriate for all distribution panels and frames with keystone outbreak
- Extremely small design „Slimline“ for installation with UAE frame sets, design capable
- Independent 360°-shield contact and strain relief of the cable with two cable ties
- Flexibel strain relief for different cable diameter
- Captive dust cover
- Separate grounding contact at the back side

Technical data

Electrical properties:

- Insulation resistance: > 500 MΩ
- Dielectric Withstand voltage: 1000V AC RMS 60 Hz
- Contact resistance: <20 MΩ
- Current rating: 1.5A @ 20 °C
- EMC to EN 50082-1, EN 55022

- PVP-certified
- Separate grounding contact at the back side
- Cat.6_A component certified to ISO/IEC 11801 Ed.2.2 (2011-06)
- Standards : ISO/IEC 11801 Ed.2.2 (2011-06)
IEC 60603-7-51 Ed.1.1 (2010-03)

Mechanical properties:

- Mating cycles > 750 cycles
- Temperature range (storage and operating): -40 °C ~ +66 °C
- Contact Plating: 50µ" gold



Art.No.	E-20095	File	E-20095.indd		
Description	INFRALAN® RJ45 Keystone Slimline, Cat.6 _A , silver, STP, components certified				
Created	Date	Last revision	Date	Proved	Date
BF	05.08.2016	AM	28.02.2017	BF	13.09.2016

DATASHEET

Drawings/ Figures

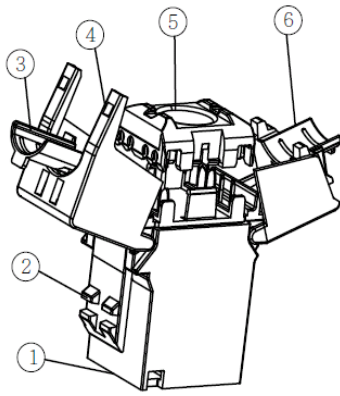

1, 3, 4, 6 - Zn alloy
2, 5 - PC

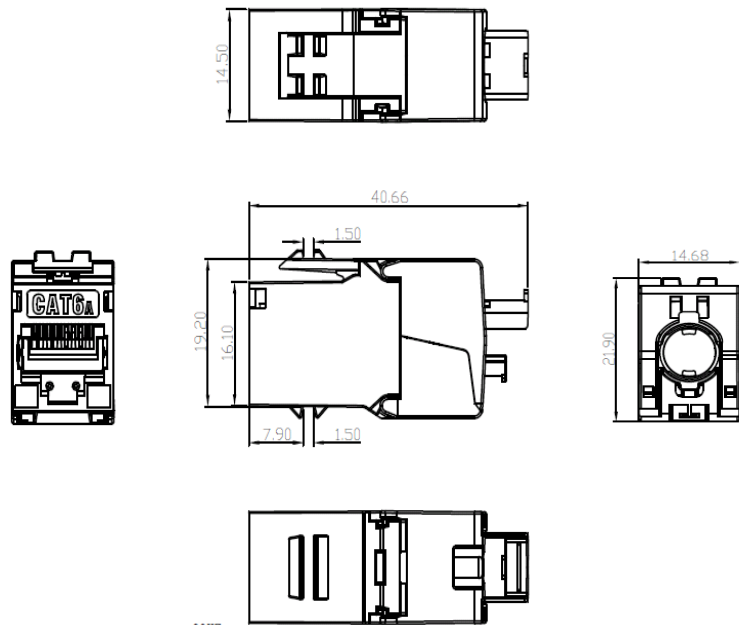

Packing information

- 1 piece in polybag, printed with instruction manual
- Included accessories: 1 x RJ45 keystone, 1 x captive dust cover, 1 x copper foil, 2 x cable ties, mounting instruction



Order data

Art. No.	Typ
E-20095	INFRALAN® RJ45 Keystone Slimline, Cat.6A, silver, STP, components certified
Art. No.	Typ
37578.1-IF	INFRALAN® 19" 1U Distribution Panel for 24 Keystone modules, black (RAL9005)
37580.2-IF	INFRALAN® 19" 1U Distribution Panel for 24 Keystone modules, grey (RAL7035)
ET-25090	Frame set for 2 x Keystones module slimline, RJ45, design capable
ET-25111	Keystone Frame 2 x for Keystones

Art.No.	E-20095	File	E-20095.indd		
Description	INFRALAN® RJ45 Keystone Slimline, Cat.6A, silver, STP, components certified				
Created	Date	Last revision	Date	Proved	Date
BF	05.08.2016	AM	28.02.2017	BF	13.09.2016